

OPERATING INSTRUCTIONS



SZ-7504



INDIA

www.subzero.co

Introduction:

4 Channel Temperature Scanner (SZ-7504)

Temperature Indicators and Controllers play an important part in any industry. Quick and accurate measurement and control of process temperature will help to improve the final product quality, reliability and reduce rejection. Temperature indication and control is therefore one of the prime consideration in any industry.

SZ-7504 is a temperature scanner, which accepts thermistor as input.

Features:

1. Range: -50 to +99 C in 1 deg. Resolution.
2. Highly Compact.
3. AUTO/MANUAL mode selection.
3. Fully Configurable from keyboard.
4. Keypad lock facility.
5. Alarm Relay output for fault indication.

1

Operation:

In its AUTO running mode, the scanner keeps on selecting successive channels (unless skipped) and displays the temperature of a channel for the programmed Scan Time. MANUAL Mode is used for monitoring single channel data.

Alarm will come on for any active channel, the data of which has crossed any of the programmed High set limits or Low set limit value or incase of probe failure. These alarm limits can be programmed by the user from the front keypad. In case of a fault, relay will energize and front LED corresponding to that channel will flash while displaying temperature. Alarm can be acknowledged by MUTE key on front.

2

INDEX

Para.	Page	Description
	4	Selection of Scan mode.
	5	How to set other parameters.
CH1	6	To Activate/Deactivate channnels.
CH2	7	To Activate/Deactivate channnels.
CH3	8	To Activate/Deactivate channnels.
CH4	9	To Activate/Deactivate channnels.
P2	10	Max High Temp limit & alarm.
P3	11	Min Low Temp limit & alarm.
P5-1	12	Probe calibration of channels.
P5-2	13	Probe calibration of channels.
P5-3	14	Probe calibration of channels.
P5-4	15	Probe calibration of channels.
St	16	Set Scan Time.
LP	17	Keypad Lock.
AL	18	Alarm - To activate Alarm Relay.
FS	19	Restore factory defaults.
EP	20	End Programming & Keypad functions.
	21	Operating messages.
	23	Wiring diagrams.
	24	Panel cutout & dimensions.

3

Selection of Scan Mode:

User can select AUTO / MANUAL mode by pressing AUTO/MAN key for 2 seconds.

1. AUTO MODE: Normally Scanner is in AUTO mode where temperature of all active channels is displayed sequentially at the programmed Scan Time. While displaying temperature, LED corresponding to that channel will be ON. In this mode AUTO LED will be ON and MANUAL LED will be OFF.

2. MANUAL MODE: In this mode user can view data of selected channel. In this mode MANUAL LED will be ON and AUTO led will be OFF.

As soon as AUTO/MAN key is pressed for 2 seconds the display will stop at the currently displayed channel. User can see temperature of NEXT or PREVIOUS active channel by pressing UP/DOWN keys.

4

To set parameters.	
Press & hold DOWN(prg) key for 2 seconds.	Display will show CH 1 & flash. To go to other parameters, use UP / DOWN keys.
	
5	

CH - 1	Function: To Activate/De-activate channels.	
To set the CH 1 Parameter, press the SET key.	Use UP/DOWN keys to set desired channel. 0 = De-active channel. 1 = Active Channel.	
	Similarly user can Activate or deactivate remaining channels. To move between channels press UP/DOWN keys.	
Min	Max	Fac.
0	1	1
If all channels are inactive, display will show nS. When user activates any one channel, scanner will reset for first time.		
6		

CH - 2	Function: To Activate/De-activate channels.	
To set the CH 2 Parameter, press the SET key.	Use UP/DOWN keys to set desired channel. 0 =De-active channel. 1= Active Channel.	
	Similarly user can activate or deactivate remaining channels. To move between channels press UP/DOWN keys.	
Min	Max	Fac.
0	1	1
If all channels are inactive, display will show nS. When user activates any one channel, scanner will reset for first time.		
7		

CH - 3	Function: To Activate/De-activate channels.	
To set the CH 3 Parameter, press the SET key.	Use UP/DOWN keys to set desired channel. 0 =De-active channel. 1= Active Channel.	
	Similarly user can activate or deactivate remaining channels. To move between channels press UP/DOWN keys.	
Min	Max	Fac.
0	1	1
If all channels are inactive, display will show nS. When user activates any one channel, scanner will reset for first time.		
8		

CH - 4	Function: To Activate/De-activate channels.	
To set the CH 4 Parameter, press the SET key.	Use UP/DOWN keys to set desired channel. 0 =De-active channel. 1= Active Channel.	
	Similarly user can activate or deactivate remaining channels. To move between channels press UP/DOWN keys.	
Min	Max	Fac.
0	1	1
If all channels are inactive, display will show nS. When user activates any one channel, scanner will reset for first tie.		
9		

P2 parameter	Function: To set max allowable High temp. Limit and Alarm.	
To change the parameter, press the SET key.	Use UP/DOWN keys to set desired range. Once set at a particular range, this will not allow the P3 parameter to go above this range.	
	Example : Setting this parameter at 65°C will not allow the P3 parameter to go above 64°C. Also, if the temperature of any active channel reaches 65°C, the LED corresponding to that channel will flash while displaying temperature and Alarm will come ON.	
Min	Max	Fac.
XX°C	99°C	99°C
10		

P3 parameter			Function: To set max allowable low temp. Limit.
To change the P3 parameter, press the SET key.			Use UP/DOWN keys to set desired range. Once set at a particular range, this will not allow the P2 parameter to go below this range.
Min	Max	Fac.	Example : Setting this parameter at -25°C will not allow the P2 parameter to go below -24°C. Also, if the temperature of any active channel reaches -24°C, the LED corresponding to that channel will flash while displaying temperature and Alarm will come ON.
-50°C	XX°C	-50°C	

11

P5 - 1			Function: To set probe calibration of channels.
To change the P5 parameter, press the SET key.			Use UP/DOWN keys to set desired range. In time it may be possible that the display may be offset by a degree or so. To compensate for this error, you may need to add or minus the degrees required to achieve the correct temperature. Setting range is from -10°C to +10°C.
Min	Max	Fac.	Example: The temperature on the display is 28°C, whereas the actual temperature is 30°C. You will need change the P5 setting of that channel to 2°C, which means that once out of the programming mode, the display will show 30°C (28°C + 2°C).
-10°C	10°C	0°C	

12

P5 - 2			Function: To set probe calibration of channels.
To change the P5 parameter, press the SET key.			Use UP/DOWN keys to set desired range. In time it may be possible that the display may be offset by a degree or so. To compensate for this error, you may need to add or minus the degrees required to achieve the correct temperature. Setting range is from -10°C to +10°C.
Min	Max	Fac.	Example: The temperature on the display is 28°C, whereas the actual temperature is 30°C. You will need change the P5 setting of that channel to 2°C, which means that once out of the programming mode, the display will show 30°C (28°C + 2°C).
-10°C	10°C	0°C	

13

P5 - 3			Function: To set probe calibration of channels.
To change the P5 parameter, press the SET key.			Use UP/DOWN keys to set desired range. In time it may be possible that the display may be offset by a degree or so. To compensate for this error, you may need to add or minus the degrees required to achieve the correct temperature. Setting range is from -10°C to +10°C.
Min	Max	Fac.	Example: The temperature on the display is 28°C, whereas the actual temperature is 30°C. You will need change the P5 setting of that channel to 2°C, which means that once out of the programming mode, the display will show 30°C (28°C + 2°C).
-10°C	10°C	0°C	

14

P5 - 4			Function: To set probe calibration of channels.
To change the P5 parameter, press the SET key.			Use UP/DOWN keys to set desired range. In time it may be possible that the display may be offset by a degree or so. To compensate for this error, you may need to add or minus the degrees required to achieve the correct temperature. Setting range is from -10°C to +10°C.
Min	Max	Fac.	Example: The temperature on the display is 28°C, whereas the actual temperature is 30°C. You will need change the P5 setting of that channel to 2°C, which means that once out of the programming mode, the display will show 30°C (28°C + 2°C).
-10°C	10°C	0°C	

15

St			Function: To set scan time.
To change the St parameter press the SET key.			Use UP/DOWN keys to set desired range.
			In AUTO mode, temperature of all active channels is displayed sequentially for programmed Scan time.
Min	Max	Fac.	
1sec.	10sec.	3sec.	

16

LP parameter			Function: To lock keypad.
To change LP parameter press the SET key.			Use UP/DOWN keys to set desired range. This parameter can lock the keypad so that tempering is not possible by by-standers. 0 = keypad unlocked 1 = keypad locked
Min	Max	Fac.	
0	1	0	
			When locked all parameters can only be viewed, but not modified.

17

AL parameter			Function: To activate/deactivate alarm relay.
To change the AL parameter, press the SET key.			Use UP/DOWN keys to set alarm on or off. Once set to on, the alarm relay will activate incase the temperature goes above or below the points set in parameter P2 & P3 and if the probe fails. 0= De-activates alarm relay. 1= Activates alarm relay.
Min	Max	Fac.	
0	1	1	
			Note : If High temp. or low temp. or probe fail fault occurs on any particular active channel, Alarm relay will energize. User can acknowledge the Alarm by pressing RST key. After acknowledging Alarm, if new fault occurs on another active channel, alarm relay will energize again.

18



FS parameter			Function : To restore default settings of the controller.
To change the FS parameter, press the SET key.			When set to 1 all parameters are programmed to factory values. Useful to debug setting related problems.
Min	Max	Fac.	
0	1	0	

19

EP parameter			Function: To end programming.
To end programming press the set key.			Once the set key is pressed, the control goes into the normal mode and displays the temperature and all settings are recorded.

20

Operating messages and Icon status

Message	Description	Parameter
Ht	Temperature above the maximum limit of the set point.	P2
Lt	Temperature below the minimum limit of the set point.	P3
PP	Probe short circuit, circuit open or without probe, or temperature > 99°C or <-50°C.	
1  Flashing	Incise of a channel LED flashing, it indicates that there is an Ht or Lt error.	
1  ON	Incise the channel LED is on, it indicates display is showing the temperature of that particular channel.	

21

<p>Technical data : Housing : Black, ABS Plastic Front Cover : Red Polycarbonate plastic. Dimensions : Front : 77 X 34.5 mm, Depth : 71 mm (w/o back lid). Panel Cutout : 29 X 71 mm Mounting : Flush panel mounting with fasteners. Protection : Front panel is waterproof& I.P 65 rated. Connections : Screw terminal blocks. ≤ 2.5 mm² wiring. Display : 2 X14.2 mm 0.56" LED. Data storage : Non-volatile EEPROM memory. Operating temp. : 5°C to 50°C(non-condensing). Alarm relay : 250Vac 5A(res.), 1 NO,C . Storage temp : -20°C to 70°C (non-condensing). Input : NTC probe , SZ-N75. Range : -50°C to +99°C. Resolution : 1°C. Accuracy : +/- 1°C. Probe tolerance at 25°C : +/- 0.3°C. Power input: 230Vac ± 10%,50-60Hz.Other on request</p>

22

WIRING DIAGRAM

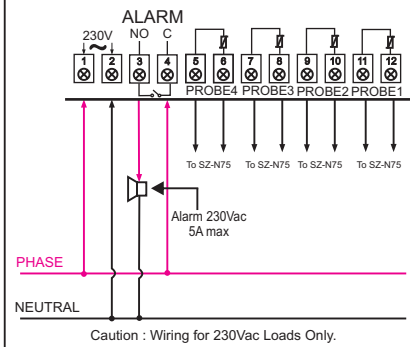

23

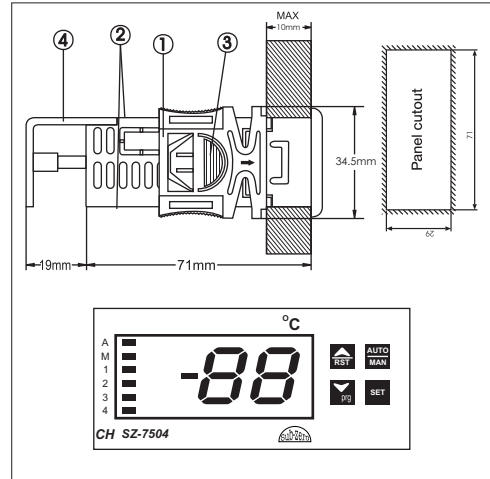

24

Installation : Fixing and dimensions of panel models:

To fix the unit, slide the fastener ① through the guides ② as per the position shown in the figure. Move the fastener in the direction of the arrow, pressing tab ③ it permits to move the fastener in the opposite direction of the arrow. Once the controller has been connected, they should be covered with the lid ④.

Silicon sealant should be applied along the perimeter of the panel cut out or a rubber 'O' ring supplied before the unit is fitted to increase protection against water seepage.

Controller : Controller should be installed in a place protected by vibration, water and corrosive gasses and where ambient temperature does not exceed the values specified in the technical data.

Probe : To give a correct reading, the probe must be installed in a place protected from thermal influences, which may affect the temperature to be controlled.

25

CAUTION

WIRING: The probe and its corresponding wires should never be installed in a conduit next to control or power supply lines. The electrical wiring should be done as shown in the diagram. The power supply circuit should be connected to a protection switch. The terminals admit wires of upto 2.5sq mm.

WARNING: Improper wiring may cause irreparable damage and personal injury. Kindly ensure that wiring is done by qualified personnel only.

Maintenance: Cleaning: Clean the surface of the controller with a soft moist cloth. Do not use abrasive detergents, petrol, alcohol or solvents.

Notice: The information in this document is subject to change in order to improve reliability, design or function without prior notice and does not represent a commitment on the part of the company. In no event will the company be liable for direct, indirect, special, incidental or consequential damage arising out of the use or inability to use the product or documentation, even if advised of the possibility of such damages. No part of this manual may be reproduced or transmitted in any form or by any means without the prior written permission of the company.

26

Disclaimer: This manual & its contents remain the sole property of A.S. CONTROLS Pvt. Ltd, India and shall not be reproduced or distributed without authorisation. Although great care has been taken in the preparation of this document, the company or its vendors in no event will be liable for direct, indirect, special, incidental or consequential damage arising out of the use or inability to use the product or documentation, even if advised of the possibility of such damages. No part of this manual may be reproduced or transmitted in any form or by any means without the prior written permission of the company. A.S. CONTROLS Pvt. Ltd, reserves the right to make and changes or improvements without prior notice.

Warranty: This product is warranted against defects in materials and workmanship for a period of one year from the date of purchase. During the warranty period, product determined by us to be defective in form or function will be repaired or, at our option, replaced at no charge. This warranty does not apply if the product has been damaged by accident, abuse, and misuse or as a result of service or modification other than by the company. This warranty is in lieu of any other warranty expressed or implied. In no event shall the company be held liable for incidental or consequential damages, including lost revenue or lost business opportunity arising from the purchase of this product..

27

OUR OTHER PRODUCTS



Cold Room Controller
Chiller Controller
Two Compressors Controller
Heating Controller
Humidity Controller
Pressure Controller



Ball Valves
Globe Valves
Hand Valves
Flow Switches
Solenoid Valves