

OPERATING INSTRUCTIONS

SZ-7081



General Description

The **SZ-7081** is a single setpoint temperature controller. It have an unique features and user friendly parameters. It is designed for Heating as well as Cooling applications. In Heating mode they can work in either Proportional or On-Off mode.

Additionally the SZ-7081 offer several protection features that are easily understood by the examples given in the instruction manual.

The SZ-7081 can be used for several applications with measuring range as below:

- J type thermocouple : 0 °C to 700 °C
- K type thermocouple : 0 °C to 900 °C
- 2 Wire RTD : -99 °C to 850 °C
- 3 Wire RTD : -99.9 °C to 99.9 °C

Technical Data

Housing	Black, ABS Plastic.
Dimensions	Front - 75.5x35mm Depth- 87mm
Mounting	Flush panel mounting with fasteners.
Frontal protection	IP 54.
Connections	Screw terminal blocks. ≤ 1.5 sq mm one wire/ terminal only.
Display	4 digits display, size 0.56" (7 segments)
Data storage	Non-volatile EEPROM memory.
Power input	100 to 265 Vac Others on request.
Operating temp.	5°C to 50°C (non-condensing).
Storage temp	-20°C to 70°C (non-condensing).
Input	Tc J or Tc K or RTD 2/3 wires
Resolution	0.1°C for 3 wire RTD & 1°C for 2 wire RTD ,J, K.
Accuracy	± 0.1% of full scale/ ± 1°C
Sensor Type	RTD/ J / K
LED status	1. Relay On/Off 2. SSR On/Off 3. "J" 4. "K" 5. "RTD"
Control Action	1. Proportional 2. On-Off
Relay Mode	Heating / Cooling.
Output	1 SPDT relay 5A/250Vac or SSR (selectable)
Probe Fail Action	Relay OFF
Contacts	C-NO-NC

Front Panel View

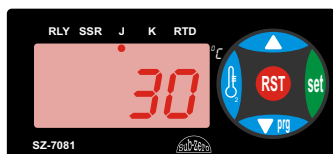

Installation and Dimensions

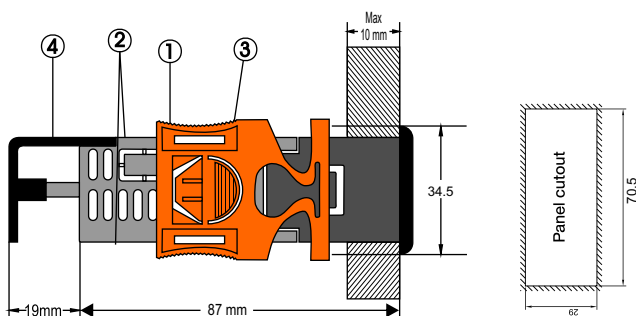

To fix the unit, slide the fastener ① through the guides ② as per the position shown in the figure. Move the fastener in the direction of the arrow, pressing tab ③ it permits to move the fastener in the opposite direction of the arrow. Once the controller has been connected, they should be covered with the lid ④. Silicon sealant should be applied along the perimeter of the panel cut out or a rubber 'O' ring supplied before the unit is fitted to increase protection against water seepage.

Controller: Controller should be installed in a place protected by vibration, water and corrosive gasses and where ambient temperature does not exceed the values specified in the technical data.

Operating Messages And Icon Status

Message	Mode	Description	Parameter
<i>Ht</i>	Flashing	Temperature equal or above the maximum limit of the set point.	<i>HSLt</i>
<i>Lt</i>	Flashing	Temperature equal or below the minimum limit of the set point.	<i>LSLt</i>
<i>SF</i>	Flashing	Probe circuit open or without probe or temperature out of given range.	

Min = Minimum, **Max** = Maximum **Fac.** = Factory Setting (Default)

1. Set Point: To set Cutout value of relay/SSR.

Min	Max	Fac.
<i>LSLt</i>	<i>HSLt</i>	0



- Press and hold the "SET" key for 2 Seconds.
- The set value will start flashing.
- Use ▲ or ▼ to set the desired value.
- Press "SET" key & you will see "- -" which confirms that the set point has been stored in memory.

Once the set key is pressed, the control goes into the normal mode.

Parameter List

2. To set other Parameters



- Press & hold the pg key for 2 seconds.
- Display will show "inPt" & flash.
- To go to other parameters, use ▲ or ▼ keys.

3. inPt Parameter : To select the type of sensor.

Min	Max	Fac.
<i>tC-J</i>	<i>rtd2</i>	<i>tC-J</i>

- To change the inPt parameter, press the "SET" key.
- To go to desired value, use ▲ or ▼ keys.
- To set confirm value press "SET" key you will see "- -" which confirms that the value has been stored in memory.

tC-J : J type Thermocouple.

tC-K : K type Thermocouple.

rtd2 : 2 wire RTD.

rtd3 : 3 wire RTD.

Note : If sensor type is changed ,following parameters will be changed to their factory set values.

HSLt = 700(J) / 999(K) / 850(rtd2) / 99.9(rtd3),

LSLt = 0(J/K), -99(rtd2), -99.9(rtd3)

CALb = 0 & *SET* = 0

4. out Parameter : To select the type of output.

Min	Max	Fac.
<i>rLY</i>	<i>SSr</i>	<i>rLY</i>

- To change the out parameter, press the "SET" key.
- To go to desired value, use ▲ or ▼ keys.
- To set confirm value press "SET" key you will see "- -" which confirms that the value has been stored in memory.

rLY : Relay

SSr : SSR

OPERATING INSTRUCTIONS

5. *H-C* Parameter : To set relay mode as per application.

Min	Max	Fac.
HEAt	COOL	HEAt

- To change the *H-C* parameter, press the "SET" key.
- To go to desired value, use ▲ or ▼ keys.
- To set confirm value press "SET" key you will see "--" which confirms that the value has been stored in memory.

HEAt - Heating (Forward).
COOL - Cooling (Reverse).

Note: If "H-C" is selected as "Cool" (cooling mode), "Ctrl" parameter (Control action) will be set to "onof".

6. *Ctrl* Parameter : To set Control Action of Output.

Min	Max	Fac.
onof	PrOP	PrOP

- To change the *Ctrl* parameter, press the "SET" key.
- To go to desired value, use ▲ or ▼ keys.
- To set confirm value press "SET" key you will see "--" which confirms that the value has been stored in memory.

onof - On - Off mode.
PrOP - Proportional mode.

Note : If "H-C" parameter is selected as "Cool", Control action can not be selected as "ProP".

7. *Prbd* Parameter : To set Proportional Band.
This parameter is activated in Proportional Mode only.

Min	Max	Fac.
0.1°C	99.9°C	10.0°C

- To change the *Prbd* parameter, press the "SET" key.
- To go to desired value, use ▲ or ▼ keys.
- To set confirm value press "SET" key you will see "--" which confirms that the value has been stored in memory.

This is the Proportional Band set in degrees.

Example: If Set point is 60°C & Proportional band(Prbd) is 10°C, then proportional action takes place between 50°C to 60°C.

8. *Hyst* Parameter : To set Hysterisis (differential).
This parameter is activated in On-Off mode only.

Min	Max	Fac.
0.1°C	99.9°C	2.0°C

- To change the *Hyst* parameter, press the "SET" key.
- To go to desired value, use ▲ or ▼ keys.
- To set confirm value press "SET" key you will see "--" which confirms that the value has been stored in memory.

This parameter value is the differential between cut out and cut-in temperature.

Example: (In cooling mode): If the set point is 40.0°C and Hysterisis is set at 2.0°C then, when the system reaches 40.0°C, the Relay will cut out. Since the Hysterisis is 2.0°C, the Relay will cut in (restart) at 42.0°C (40.0°C+2.0°C).

(In Heating mode): If the set point is 40.0°C and Hysterisis is set at 2.0°C then, when the system reaches 40.0°C, the Relay will cut out. Since the Hysterisis is 2.0°C, the Relay will cut in (restart) at 38.0°C (40.0°C-2.0°C).

9. *CYt* Parameter : To set cycle Time in seconds.
Activated in Proportional mode only.

Min	Max	Fac.
1Sec	99Sec	20Sec

- To change the *CYt* parameter, press the "SET" key.
- To go to desired value, use ▲ or ▼ keys.
- To set confirm value press "SET" key you will see "--" which confirms that the value has been stored in memory.

Example: If Cycle Time is set to 10 sec, the duty cycle of Relay/SSr ON-OFF in proportional band will be 10 sec.

ON time +OFF time = 10 sec.

10. *oFSt* Parameter : To set manual offset for proportional band.
Activated in Proportional mode only.

Min	Max	Fac.
-99.9°C	99.9°C	0.0°C

- To change the *oFSt* parameter, press the "SET" key.
- To go to desired value, use ▲ or ▼ keys.
- To set confirm value press "SET" key you will see "--" which confirms that the value has been stored in memory.

This parameter decides the position of Proportional band.

Example: If "oFSt" is 0.0°C, Set point is 60°C, Prbd = 10.0°C, then proportional band is 50°C to 60°C (Proportional action will take place between 50°C to 60°C). But for the same settings of Set point and Prbd, if "oFSt" is set to 5.0°C, then proportional band will be 55°C to 65°C.

11. *tDLy* Parameter : To set Time Delay.

This parameter is activated in On-Off Mode only.

Min	Max	Fac.
0 Min	20 Min	0 Min

This parameter is used to protect the compressor from restarting in a short period of time.

- To change the *tDLy* parameter, press the "SET" key.
- To go to desired value, use ▲ or ▼ keys.
- To set confirm value press "SET" key you will see "--" which confirms that the value has been stored in memory.

Example: If this parameter is set to 3 minutes, the Relay will cut off at the set temperature, but will not restart for 3 minutes even if the differential is achieved earlier. This parameter is good to protect the life of the compressor or even in applications where the probe is placed at places where there are sudden & short changes in temperature.

12. *HSLt* Parameter : To set maximum limit for set point as per the sensor selected.

Min	Max	Fac.
Set Point	700°C (J) 999°C (K) 850°C (Rtd2) 99.9°C (Rtd3)	700°C

- To change the *HSLt* parameter, press the "SET" key.
- To go to desired value, use ▲ or ▼ keys.
- To set confirm value press "SET" key you will see "--" which confirms that the value has been stored in memory.

Example: Setting this parameter at 60.0°C will not allow the set point to go above 60.0°C. Also, if the temperature reaches 60.0°C or above, the display will show *Ht* (High Temp) indicating that the temperature has gone above the value in this parameter.

13. *LSLt* Parameter : To set minimum limit for set point as per the sensor selected.

Min	Max	Fac.
0°C (J) 0°C (K) -99°C (rtd2) -99.9°C (rtd3)	Set point	0°C

- To change the *LSLt* parameter, press the "SET" key.
- To go to desired value, use ▲ or ▼ keys.
- To set confirm value press "SET" key you will see "--" which confirms that the value has been stored in memory.

Example: Setting this parameter at 20.0°C will not allow the set point to go below 20.0°C. Also, if the temperature reaches 20.0°C or below, the display will show *Lt* (Low Temp) indicating that the temperature has gone below the value in this parameter.

14. *CALb* Parameter : To set Probe calibration.

Min	Max	Fac.
-20°C/ -20.0°C (rtd3)	20°C/ 20.0°C (rtd3)	0°C

- To change the *CALb* parameter, press the "SET" key.
- To go to desired range, use ▲ or ▼ keys.
- To set confirm value press "SET" key you will see "--" which confirms that the value has been stored in memory.

Example: The temperature on the display is 28.0°C, whereas the actual temperature is 30.0°C. You will need to set the "CALb" parameter to 2.0, which means that once out of the programming mode, the temperature will show 30.0°C (28.0°C + 2.0°C).

15. *LOCK* Parameter : To lock keypad.

Min	Max	Fac.
no	YES	no

- To change the *LOCK* parameter, press the "SET" key.
- To go to desired range, use ▲ or ▼ keys.
- To set confirm value press "SET" key you will see "--" which confirms that the value has been stored in memory.

This parameter locks the keypad so that tampering is not possible by bystanders.

no : keypad unlocked.
YES : keypad locked.

When locked, all the parameters can only be viewed, but can't be modified & when you enter the parameter it will display "LOCK" and then it will show the value of parameter.

OPERATING INSTRUCTIONS

16. *rESt* Parameter : To restore default settings.

Min	Max	Fac.
no	YES	no

1. To change the *rESt* parameter, press the "SET" key.
2. To go to desired value, use ▲ or ▼ keys.
3. To set confirm value press "SET" key you will see "--" which confirms that the value has been stored in memory.

When set to "YES", all parameters are programmed to factory set values. Useful to debug setting related problems.

17. *End* Parameter : To end programming.

Once the SET key is pressed, the control goes into the normal mode and displays the temperature and all settings are recorded.

Wiring Diagram

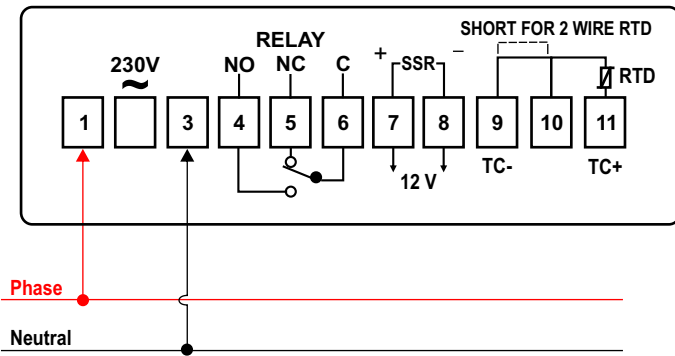

Caution: Wiring for 230Vac load only

Caution

WIRING: The probe and its corresponding wires should never be installed in a conduit next to control or power supply lines. The electrical wiring should be done as shown in the diagram. The power supply circuit should be connected to a protection switch. The terminals admit wires of upto 2.5sq mm.

WARNING: Improper wiring may cause irreparable damage and personal injury. Kindly ensure that wiring is done by qualified personnel only.

MAINTENANCE: Cleaning: Clean the surface of the controller with a soft moist cloth. Do not use abrasive detergents, petrol, alcohol or solvents.

NOTICE: The information in this document is subject to change in order to improve reliability, design or function without prior notice and does not represent a commitment on the part of the company. In no event will the company be liable for direct, indirect, special, incidental or consequential damage arising out of the use or inability to use the product or documentation, even if advised of the possibility of such damages. No part of this manual may be reproduced or transmitted in any form or by any means without the prior written permission of the company.

DISCLAIMER: This manual & its contents remain the sole property of ACR Instruments & Valves Pvt. Ltd., H.P., India and shall not be reproduced or distributed without authorization. Although great care has been taken in the preparation of this document, the company or its vendors in no event will be liable for direct, indirect, special, incidental or consequential damage arising out of the use or inability to use the product or documentation, even if advised of the possibility of such damages. No part of this manual may be reproduced or transmitted in any form or by any means without the prior written permission of the company. ACR Instruments & Valves Pvt. Ltd., H.P., reserves the right to make and changes or improvements without prior notice.

WARRANTY: This product is warranted against defects in materials and workmanship for a period of one year from the date of purchase. During the warranty period, product determined by us to be defective in form or function will be repaired or, at our option, replaced at no charge. This warranty does not apply if the product has been damaged by accident, abuse, and misuse or as a result of service or modification other than by the company. This warranty is in lieu of any other warranty expressed or implied. In no event shall the company be held liable for incidental or consequential damages, including lost revenue or lost business opportunity arising from the purchase of this product.