

OPERATING INSTRUCTIONS

SZ-7510/15/20/25/29/69-P



General Description

The Sub-Zero Series 75XX-P are aesthetically superior versions of their predecessors. The SZ 7510-P is a single set point controller. The SZ 7515/25-P is a single set point controller with buzzer. The 7520/25-P is a defrost controller, and 7529-P is also a defrost controller with an inbuilt power relay which can drive compressor loads directly upto 20Amps, thereby eliminates use of contactor in single phase applications. They are specifically designed for refrigeration applications wherein the compressor cuts off at set point and is restarted at a temperature of set point plus differential.

Additionally these controllers offer several protection features that are easily understood by the examples in the instructions below. The controller can be used for heating applications, when the P1 parameter is set to "1" except for SZ-7520/25/29-P.

A number of parameters are displayed alphanumerically to set up the instrument for each specific application.

The SZ-7510/15/20/25/69/29-P controller can be used for several applications with a measuring range from -50°C to 99°C.

Technical Data

Housing	Black, ABS Plastic.
Front Cover	Red Polycarbonate plastic.
Dimensions	Front : 75 X 34.5 MM Depth : 71 MM (w/o back lid)
Panel Cutout	29 X 70.5 MM
Mounting	Flush panel mounting with fasteners.
Frontal protection	IP 65.
Connections	Screw terminal blocks. ≤ 2.5 sq mm one wire/ terminal only.
Display	2 X 14.2 mm (0.56") LED
Data storage	Non-volatile EEPROM memory.
Power input	230Vac +/-10%,50-60Hz. Others on request.
Operating temp.	5°C to 50°C (non-condensing).
Storage temp	-20°C to 70°C (non-condensing).
Input	NTC Probe, SZ-N75.
Range	-50°C to 99°C
Resolution	1°C
Accuracy	+/- 1°C
Probe tolerance	+/- 0.3°C at 25°C

Front Panel View, Relay



Relay: 8(3)A/250Vac



Relay: 8(3)A/250Vac
Buzzer: SZ-B75. 10Vdc,10mA



Relay: 8(3)A/250Vac
Buzzer: SZ-B75. 10Vdc,10mA



Relay: 20A/250Vac



Relay: 8(3)A/250Vac



Relay: 20A/250Vac

Installation and Dimensions

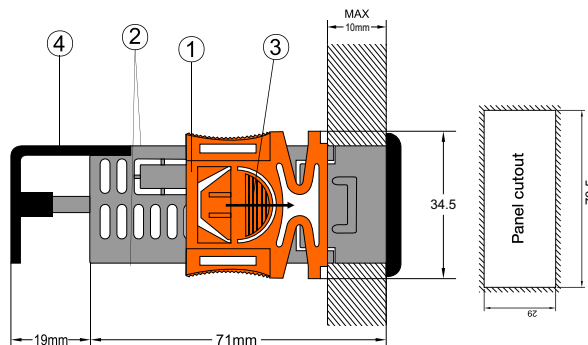

To fix the unit, slide the fastener ① through the guides ② as per the position shown in the figure. Move the fastener in the direction of the arrow, pressing tab ③ it permits to move the fastener in the opposite direction of the arrow. Once the controller has been connected, they should be covered with the lid ④. Silicon sealant should be applied along the perimeter of the panel cut out or a rubber 'O' ring supplied before the unit is fitted to increase protection against water seepage.

Controller: Controller should be installed in a place protected by vibration, water and corrosive gasses and where ambient temperature does not exceed the values specified in the technical data.

Probe: To give a correct reading, the probe must be installed in a place protected from thermal influences, which may affect the temperature to be controlled.

Operating Messages And Icon Status

Message	Mode	Description	Parameter
Ht	Flashing	Temp. above the maximum limit of the set point.	P2
Lt	Flashing	Temp. below the minimum limit of the set point.	P3
pp	Flashing	Probe short circuit, circuit open or without probe, or temperature > 99°C or < -50°C.	
❄️ ●	ON/OFF	Comp. Relay on/off.	SP, P4
❄️ ☀️	Flashing	Time delay in progress.	P6
🔑 ●	ON/OFF	Keypad locked/unlocked.	LP
❄️ ●	ON	Defrosting in progress.	P7, P8
🔔 ☀️	Flashing	Alarm (Ht, Lt or PP)	AL,P2,P3

Min = Minimum, Max = Maximum
Fac. = Factory Setting (Default)

1. Set Point : To set the cut out point.	Min	Max	Fac.
	-50°C	99°C	0°C

1. Press and hold the "SET" key for 2 Seconds.
2. The set value will start flashing.
3. Use ▲ or ▼ to set the desired value.
4. Press SET key & you will see "- - -" which confirms that the set point has been stored in memory.

Parameter List

2. To set other Parameters

1. Press & hold the prg key for 2 seconds.
2. Display will show "P1" & flash.
3. To go to other parameters, use ▲ or ▼ keys.

3. P1 Parameter : To set Heating or Cooling mode (Except-SZ-7520/25/29-P).	Min	Max	Fac.
	0	1	0

1. To change the P1 parameter, press the "SET" key.
2. To go to desired value, use ▲ or ▼ keys.

0 : Cooling mode.
1 : Heating mode.

3. To set desired value press "SET" key you will see "- - -" which confirms that the value has been stored in memory.

OPERATING INSTRUCTIONS

4. P2 Parameter : To set maximum allowable high temperature limit. (Alarm for model SZ-7515/25-P)

Min	Max	Fac.
XX°C	99°C	99°C

- To change the P2 parameter, press the "SET" key.
- To go to desired value, use ▲ or ▼ keys.
- To set desired value press "SET" key you will see "- -" which confirms that the value has been stored in memory.

Once set at a particular value, this will not allow both set points to go above this value and below P3 value.

Example: Setting this parameter at 25°C will not allow the set point to go above 25°C. Also, if the temperature reaches 25°C, the display will show Ht (High Temp.) indicating that the temperature has gone above the value in this parameter & at this point the buzzer will activate. (If AL parameter is set to 1)

(Message on display)

5. P3 Parameter : To set minimum allowable low temperature set point. (Alarm for Model SZ-7515/25-P)

Min	Max	Fac.
-50°C	XX°C	-50°C

- To change the P3 parameter, press the "SET" key.
- To go to desired value, use ▲ or ▼ keys.
- To set desired value press "SET" key you will see "- -" which confirms that the value has been stored in memory.

Once set at a particular value, this will not allow the set point to go below this value and above P2 value.

Example: Setting this parameter at -30°C will not allow the set point to go below -30°C. Also, if the temperature reaches -30°C, the display will show Lt (Low Temp.) indicating that the temperature has gone below the value in this parameter and at this point the buzzer will activate.

(Message on display)

6. P4 Parameter : To set the differential.

Min	Max	Fac.
1°C	20°C	2°C

- To change the P4 parameter, press the "SET" key.
- To go to desired value, use ▲ or ▼ keys.
- To set desired value press "SET" key you will see "- -" which confirms that the value has been stored in memory.

Example: Cooling Mode: If the set point is set at 10°C and differential is set at 2°C, then when the system reaches 10°C, the relay will cut out. Since the differential is 2, the relay will cut in (restart) at 12°C (10°C+2°C).

Heating Mode: If the set point is set at 10°C and differential is set at 2°C, then when the system reaches 10°C, the relay will cut out. Since the differential is 2, the relay will cut in (restart) at 8°C (10°C-2°C).

7. P5 Parameter : To set probe calibration.

Min	Max	Fac.
-10°C	10°C	0°C

In time it may be possible that the display may be offset by a degree or so. To compensate for this error, you may need to add or minus the degrees required to achieve the correct temperature. Setting range is from -10°C to +10°C.

- To change the P5 parameter, press the "SET" key.
- To go to desired value, use ▲ or ▼ keys.
- To set desired value press "SET" key you will see "- -" which confirms that the value has been stored in memory.

Example: The temperature on the display is 28°C, whereas the actual temperature is 30°C. You will need to set the P5 mode to 2, which means that once out of the programming mode, the temperature will show 30°C (28°C + 2°C).

8. P6 Parameter : To set time delay between relay restart time.

Min	Max	Fac.
0 Min	99 Min	3 Min

This parameter is used to protect the compressor from restarting in a short period of time and can be set between 0 to 99 minutes.

- To change the P6 parameter, press the "SET" key.
- To go to desired value, use ▲ or ▼ keys.
- To set desired value press "SET" key you will see "- -" which confirms that the value has been stored in memory.

Flashing
(Time delay in progress)

Example: If this parameter is set at 3 minutes, the relay will cut off at the set temperature, but will not restart for a minimum of 3 minutes, even if the differential is achieved earlier. This parameter is good to protect the life of the compressor when there are power fluctuations and the compressor is switched off and on within a few seconds.

9. P7 Parameter : To set duration of defrost. (For SZ-7520/25/29-P)

Min	Max	Fac.
0 Min	99 Min	0 Min

This parameter is used for auto defrost cycle and specifies how long a defrost will last.

- To change the P7 parameter, press the "SET" key.
- To go to desired value, use ▲ or ▼ keys.
- To set desired value press "SET" key you will see "- -" which confirms that the value has been stored in memory.

Example: If this parameter is set to 15min, and P8 parameter is set to 1 hr. Then '1 hr' after power is applied to the controller, defrosting for 15 minutes will take place. This cycle will repeat every 1 hour.

ON
(Defrost in progress)

 This key will start a manual defrost cycle if pressed for 2 seconds. Only in SZ-7520/29-P.

 This key will start a manual defrost cycle if pressed for 2 seconds. Only in SZ-7525-P.

10. P8 Parameter : To set the defrost frequency. (Model SZ-7520/25-P)

Min	Max	Fac.
1 hr	31 hrs	1 hr

This Parameter is used for auto defrost cycle and specifies, when each defrost cycle will be repeated.

- To change the P8 parameter, press the "SET" key.
- To go to desired value, use ▲ or ▼ keys.
- To set desired value press "SET" key you will see "- -" which confirms that the value has been stored in memory.

Example: If P7 parameter is set to 15min, and this parameter is set to 1 hr. Then '1 hr' after power is applied to the controller, defrosting for 15 minutes will take place. This cycle will repeat every 1 hour.

11. LP Parameter : To lock keypad.

Min	Max	Fac.
0	1	0

This parameter can lock the keypad so that tampering is not possible by by-standers.

- To change the LP parameter, press the "SET" key.
- To go to desired value, use ▲ or ▼ keys.

0 : keypad unlocked.
1 : keypad locked.

- To set desired value press "SET" key you will see "- -" which confirms that the value has been stored in memory.

When locked all parameters can only be viewed, but not modified.

ON/OFF
(Keypad lock)

12. AL Parameter : To activate buzzer. (Only for 7515/25-P)

Min	Max	Fac.
0	1	1

Once set to on, the buzzer will come on incase the temperature reaches or goes above or below the points set in parameter P2 & P3 and if the probe fails.

- To change the AL parameter, press the "SET" key.
- To go to desired value, use ▲ or ▼ keys.

0 : Deactivate the buzzer.
1 : Activate the buzzer.

- To set desired value press "SET" key you will see "- -" which confirms that the value has been stored in memory.

Note: Alarm will be ON in probe fail condition irrespective of AL parameter but not modified.

ON/OFF
(Buzzer)

 This key will mute the buzzer alarm. (Only SZ-7515-P)

13. E1 Parameter : To set relay status on Probe Failure.

Min	Max	Fac.
0	2	1

- To change the E1 parameter, press the "SET" key.
- To go to desired value, use ▲ or ▼ keys.

0 : Relay status is ON.
1 : Relay performs a duty cycle 10 minutes ON and 4minutes OFF.
2 : Relay status is OFF.

- To set desired value press "SET" key you will see "- -" which confirms that the value has been stored in memory.

OPERATING INSTRUCTIONS

14. **PO** Parameter : To enable/disable Power Switch.
(For SZ-7510/69-P)

Min	Max	Fac.
0	1	0



Controller has power switch, which if enabled puts controller in active or standby state. If press for 2 seconds controller will go in stand by mode, display will show "OF" To again switch to ACTIVE WORKING MODE, press power switch again for 2 seconds. All leds and 7-segment display will flash and enter into NORMAL WORKING MODE.

1. To change the PO parameter, press the "SET" key.
2. To go to desired value, use ▲ or ▼ keys.

0 : Disable power switch.
1 : Enable power switch.

3. To set desired value press "SET" key you will see "- - -" which confirms that the value has been stored in memory.

15. **FS** Parameter : To restore default settings of the controller.

Min	Max	Fac.
0	1	0

When set to 1 all parameters are programmed to factory values. Useful to debug setting related problems.

1. To change the FS parameter, press the "SET" key.
2. To go to desired value, use ▲ or ▼ keys.
3. To set desired value press "SET" key you will see "- - -" which confirms that the value has been stored in memory.

16. **EP** Parameter : To end programming.

Once the SET key is pressed, the control goes into the normal mode and displays the temperature and all settings are recorded.

Caution

WIRING: The probe and its corresponding wires should never be installed in a conduit next to control or power supply lines. The electrical wiring should be done as shown in the diagram. The power supply circuit should be connected to a protection switch. The terminals admit wires of upto 2.5sq mm.

WARNING: Improper wiring may cause irreparable damage and personal injury. Kindly ensure that wiring is done by qualified personnel only.

MAINTENANCE: Cleaning: Clean the surface of the controller with a soft moist cloth. Do not use abrasive detergents, petrol, alcohol or solvents.

NOTICE: The information in this document is subject to change in order to improve reliability, design or function without prior notice and does not represent a commitment on the part of the company. In no event will the company be liable for direct, indirect, special, incidental or consequential damage arising out of the use or inability to use the product or documentation, even if advised of the possibility of such damages. No part of this manual may be reproduced or transmitted in any form or by any means without the prior written permission of the company.

DISCLAIMER: This manual & its contents remain the sole property of ACR Instruments & Valves Pvt. Ltd., H.P., India and shall not be reproduced or distributed without authorization. Although great care has been taken in the preparation of this document, the company or its vendors in no event will be liable for direct, indirect, special, incidental or consequential damage arising out of the use or inability to use the product or documentation, even if advised of the possibility of such damages. No part of this manual may be reproduced or transmitted in any form or by any means without the prior written permission of the company. ACR Instruments & Valves Pvt. Ltd., H.P., reserves the right to make and changes or improvements without prior notice.

WARRANTY: This product is warranted against defects in materials and workmanship for a period of one year from the date of purchase. During the warranty period, product determined by us to be defective in form or function will be repaired or, at our option, replaced at no charge. This warranty does not apply if the product has been damaged by accident, abuse, and misuse or as a result of service or modification other than by the company. This warranty is in lieu of any other warranty expressed or implied. In no event shall the company be held liable for incidental or consequential damages, including lost revenue or lost business opportunity arising from the purchase of this product.

Wiring Diagram

SZ-7510/15/20/25-P

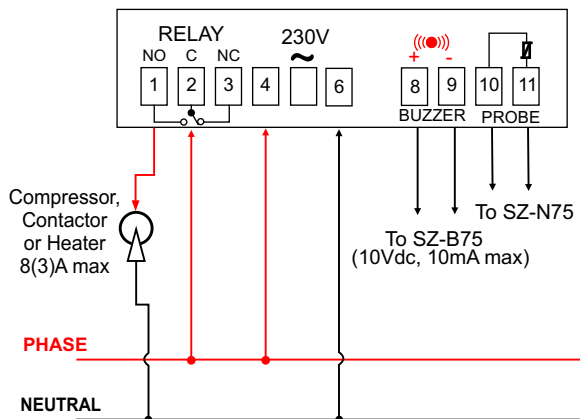

Caution: Wiring for 230Vac load only

SZ-7529/69-P

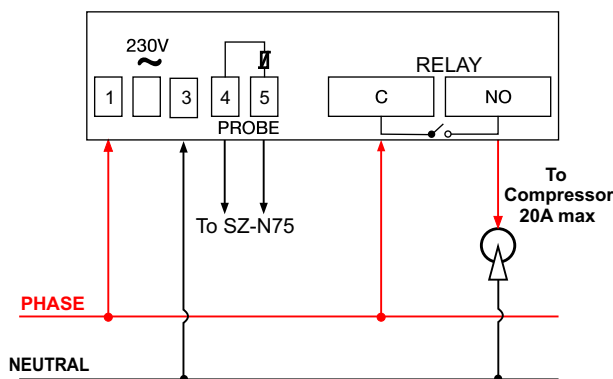

Caution: Wiring for 230Vac load only